

EB 578D

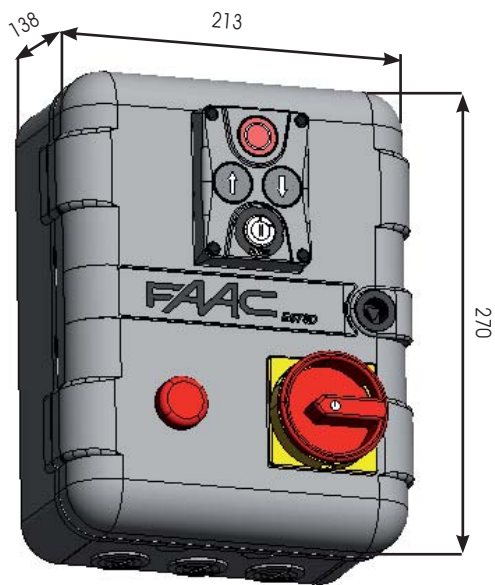

FAAC

Via Benini, 1
40069 Zola Predosa (BO) - ITALIA
Tel. 0039.051.61724 - Fax. 0039.051.758518
www.faacgroup.com



- GB -	EB 578D
Operating voltage V ~ (+6%- 10%)	230 V
Protection class	IP 54
Operating ambient temperature	-20/+55 °C
Installation	Wall

- F -	EB 578D
Tension d'utilisation V ~ (+6%- 10%)	230 V
Indice de protection	IP 54
Température d'utilisation	-20/+55 °C
Installation	Au mur

- D -	EB 578D
Betriebsspannung V ~ (+6%- 10%)	230 V
Schutzart	IP 54
Temperatur am Aufstellungsort	-20/+55 °C
Installation	Wand

- E -	EB 578D
Tensión de utilización V ~ (+6%- 10%)	230 V
Grado de protección	IP 54
Temperatura ambiente de funcionamiento	-20/+55 °C
Instalación	En pared

- NL -	EB 578D
Gebruiksspanning V ~ (+6%- 10%)	230 V
Beschermingsgraad	IP 54
Omgevingstemperatuur	-20/+55 °C
Installatie	Wand

- I -	EB 578D
Tensione di utilizzo V ~ (+6%- 10%)	230 V
Grado di protezione	IP 54
Temperatura ambiente	-20/+55 °C
Installazione	A parete

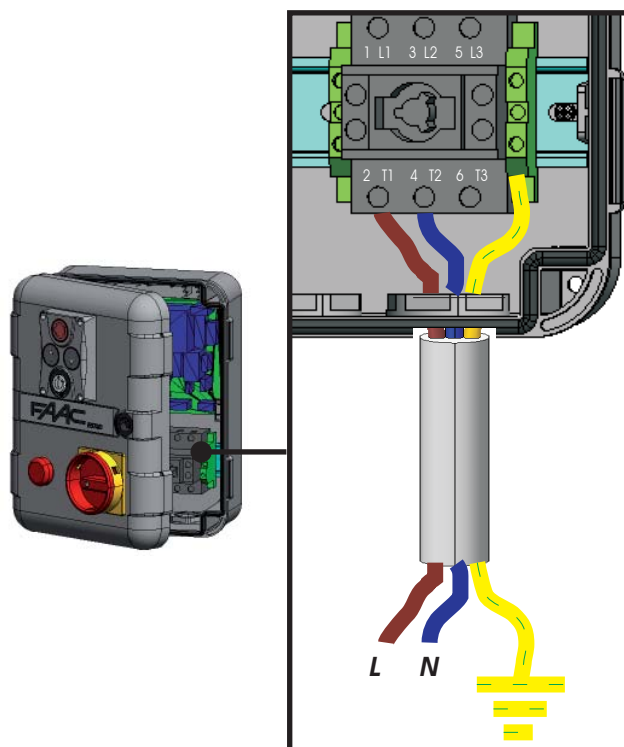
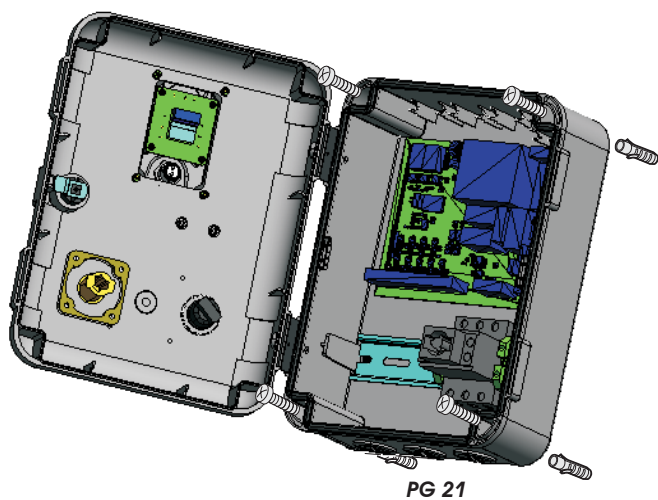



- * L'effetto sull'automazione della pressione dei tasti, varia in funzione della logica selezionata sulla centralina elettronica.
- * When the keys are pressed, the effect on the automated system varies according to the logic that was selected on the control unit.
- * L'effet de la pression des touches sur l'automatisme varie suivant la logique sélectionnée sur la centrale électronique.
- * Wenn die Tasten gedrückt werden, ändert sich die Wirkung auf die Automation je nach der Logik, die auf der elektronischen Steuereinheit angewählt wurde.
- * El efecto de la presión de las teclas en el automatismo cambia en función de la lógica seleccionada en la centralita electrónica.
- * Het effect dat de druk van de toetsen op het automatische systeem heeft, verschilt afhankelijk van de op de elektronische besturingseenheid ingestelde logica.

